



INSTALLATION INSTRUCTIONS

Accessory
FRONT BUMPER
P/N OSP70-HL6-A01

Application
**SXS1000S2X/S2XD/S2R/
S2RD/S4X/S4XD**

Publication No.
MII 17811
Issue Date
April 2022

Honda Dealer: Please give a copy of these instructions to your customer.

PARTS LIST

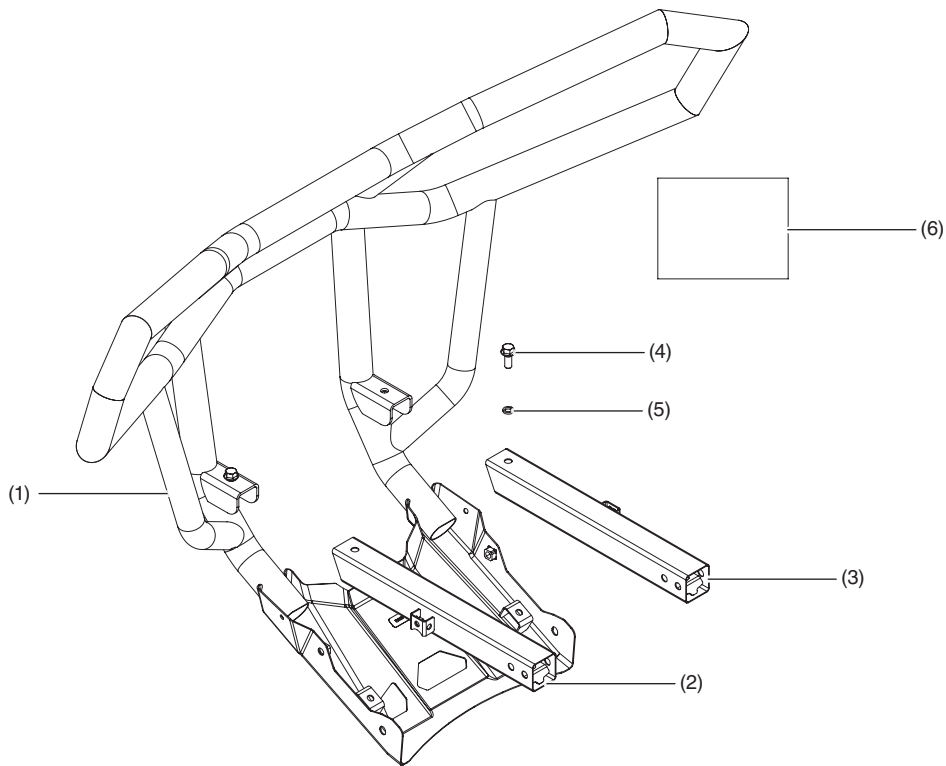

No.	Description	Qty
(1)	Front bumper assembly	1
(2)	Left mounting tube	1
(3)	Right mounting tube	1
(4)	12 x 20 mm flange bolt	2
(5)	Spring lock washer	2
(6)	Installation instructions URL	1

TORQUE CHART

Item	N·m	kgf·m	lbf·ft
12 mm flange bolt	24.5 ± 3.5	2.49 ± 0.35	18 ± 3
6 mm shoulder bolt (original bolt)	5.0 ± 0.5	0.5 ± 0.05	44 ± 4 lbf·in
5 mm socket screw (original bolt)	2.8 ± 0.2	0.28 ± 0.02	25 ± 2 lbf·in

TOOLS REQUIRED

- Socket (12 mm)
- Ratchet
- Torque wrench
- Box-end wrench (12 mm)
- 5 mm Hex wrench

INSTALLATION

⚠ CAUTION: To prevent burns, allow the engine, exhaust system, radiator, etc., to cool before the accessory.

1. Remove the original bumper. Install the left and right mounting tubes on the vehicle using the original hardware as shown.

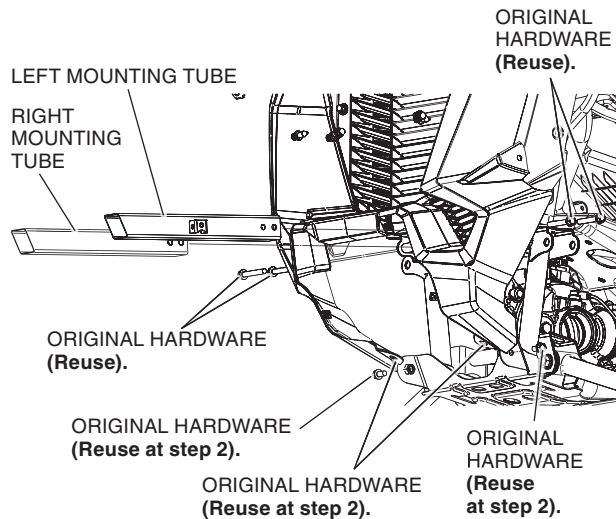

NOTE: If a winch will be installed, refer to the winch Installation Instructions, before continuing to Step 2.

2. Install the front bumper assembly on both mounting tubes with the original hardware on each side and the 12 x 20 mm flange bolts and spring lock washers as shown.

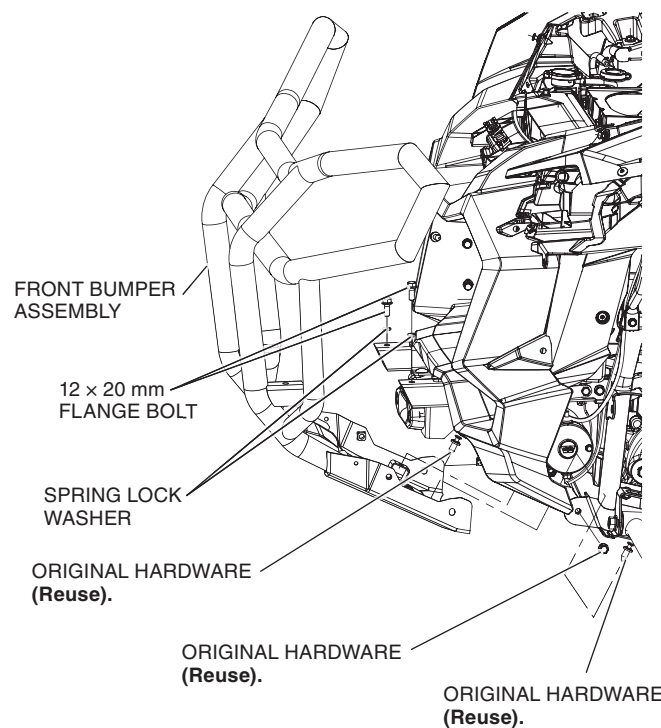

3. Tighten all the bolts to the values specified in the TORQUE CHART.